

General Description

The KY32xx series devices are EIA/TIA-232 and V.28/V.24 communication interfaces achieve 1µA supply current with KEYSEMI's revolutionary POWERSAVE™ feature. A proprietary, high- efficiency, dual charge-pump regulated voltage converters and a low-dropout transmitter combine to deliver true RS-232 performance from a single +3.0V to +5.5V supply.

These devices can operate from input voltages ranging from +3.0V to +5.5V at the guaranteed data rate of 250k bits/sec with enhanced electrostatic discharge (ESD) protection in all RS232 I/O pins exceeding ±15kV EN61000-4-2 Air Gap Discharge and ±8kV EN61000-4-2 Contact Discharge.

The POWERSAVE proprietary function which automatically powers down the on-chip regulated voltage converters and driver circuits when a RS-232 cable is disconnected from the host interface or when a connected peripheral device is turned off. The system turns on again when a valid level is applied to any RS-232 receiver input.

Absolute Maximum Ratings (All voltages referenced to GND.)

Supply Voltage V_{CC}	-0.3V to +6V
V_+	-0.3V to +7V
V_-	-0.3V to +7V
$ V_+ + V_- $	+13V
Input Voltages	
$TxIN$, $\overline{PWRSAVE}$, \overline{SD} , \overline{EN}	-0.3V to +6V
R_IN	±15V
Output Voltages	
$TxOUT$	±13.2V
$RxOUT$, \overline{STATE}	-0.3V to ($V_{CC} + 0.3V$)
Short-Circuit Duration	
$TxOUT$	Continuous
Continuous Power Dissipation ($T_A = +70^\circ C$)	

Features

- Meets EIA/TIA-232F and CCITT V.28/V.24 specifications for V_{CC} at +3.3V ±10% and +5V ±10%
- Low POWERSAVE Current: 1µA typical, 10µA max
- Guaranteed Data Rate 250kbps
- Extended ESD Protection for RS-232 I/O Pins ±15kV HBM
- High Data Rate at 1000kbps Available on KY32xxF Series

Applications

- Battery-Powered And Hand-Held Applications
- Peripherals interface
- Portable Diagnostics Equipment
- Terminal Adapters and POS terminals
- Notebooks, Subnotebooks, and Palmtops
- Industrial and Embedded PCs

Power Dissipation Per Package

16-pin SSOP (derate 7.20mW/°C above +70°C)	584mW
16-pin nSOIC (derate 10.00mW/°C above +70°C).....	720mW
16-pin TSSOP (derate 6.80mW/°C above +70°C)	556mW
16-pin PDIP (derate 11.20mW/°C above +70°C).....	896mW
18-pin PDIP (derate 12.60mW/°C above +70°C).....	962mW
20-pin PDIP (derate 12.80mW/°C above +70°C).....	976mW
20-pin SSOP (derate 8.10mW/°C above +70°C)	647mW
20-pin TSSOP (derate 7.20mW/°C above +70°C).....	584mW
28-pin SSOP (derate 9.52mW/°C above +70°C).....	762mW
28-pin TSSOP (derate 13.20mW/°C above +70°C)	1W
32-pin VQFN (derate 29.4mW/°C above +70°C).....	2352mW
Operating Temperature Range	
Junction Temperature.....	-40°C to +85°C
Storage Temperature Range	+150°C
Lead Temperature (soldering 10s)	-65°C to +150°C
	+300°C

Stresses beyond those listed under "Absolute Maximum Ratings" may cause permanent damage to the device. These are stress ratings only, and functional operation of the device at these or any other conditions beyond those indicated in the operational sections of the specifications is not implied. Exposure to absolute maximum rating conditions for extended periods may affect device reliability.



Product Selection Guide

PART	Tx	Rx	Data Rate (kbps)	Receiver Enable	Shutdown Enable	Power Save	Number of Pins	Package Type
KY3220LEE	1	1	250	Yes	Yes	No	16	SSOP, TSSOP
KY3221 LEE	1	1	250	Yes	Yes	Yes	16	SSOP, TSSOP
KY3222 LEE	2	2	250	Yes	Yes	No	20	SSOP, TSSOP,
KY3223 LEE	2	2	250	Yes	Yes	Yes	20	SSOP, TSSOP
KY3232 LEE	2	2	250	No	No	No	16	NSOIC, SSOP, TSSOP
KY1385 LEE	2	2	250	No	Yes	No	20	SSOP
KY3243 LEE	3	5	250	No	Yes	Yes	28,32	28-SSOP, 28-TSSOP, 32-VQFN

PART	Tx	Rx	Data Rate (kbps)	Receiver Enable	Shutdown Enable	Power Save	Number of Pins	Package Type
KY3220LFE	1	1	1000	Yes	Yes	No	16	SSOP, TSSOP
KY3221LFE	1	1	1000	Yes	Yes	Yes	16	SSOP, TSSOP
KY3222LFE	2	2	1000	Yes	Yes	No	20	SSOP, TSSOP,
KY3223LFE	2	2	1000	Yes	Yes	Yes	20	SSOP, TSSOP
KY3232LFE	2	2	1000	No	No	No	16	NSOIC, SSOP, TSSOP
KY1385LFE	2	2	1000	No	Yes	No	20	SSOP
KY3243LFE	3	5	1000	No	Yes	Yes	28,32	28-SSOP, 28-TSSOP, 32-VQFN

Electrical Characteristics

(V_{CC} = +3.0V to +5.5V, C1–C4 = 0.1µF, T_A = T_{MIN} to T_{MAX}, unless otherwise noted, Typical values apply at V_{CC} = +3.3V or +5.0V and T_A = 25°C.)

Parameters	Conditions	Typical V _{CC}	Min	Typ	Max	Unit
General Info/Types						
TTL Logic Input	TxIN, $\overline{\text{PWRSAVE}}$, $\overline{\text{SD}}$, $\overline{\text{EN}}$	high ZIN				
TTL Logic Output	RxOUT, $\overline{\text{STATE}}$					
RS-232 Input	RxIN					
RS-232 Output	TxOUT					
Charge Pump Pin	C1P, C1N, C2P, C2N					
Power Pin	V _{CC} , V _{GND} , V _{DD} , V _{SS}					
Charge Pump Caps	C1P, C1N, C2P, C2N			0.1		µF
V _{CC} Voltage Range		5.0	4.5	5.0	5.5	V
		3.3	3	3.3	3.6	V
DC Characteristics						
Supply Current, Power_save disabled	$\overline{\text{PWRSAVE}} = \overline{\text{SD}} = V_{CC}$, TTL I/P = V _{CC} /GND, RS-232 I/P=float	3.3, 5.0		0.5		mA
Supply Current, Power_save enabled	$\overline{\text{PWRSAVE}} = \text{GND}$, $\overline{\text{SD}} = V_{CC}$, TTL I/P = V _{CC} /GND, RS-232 I/P=float	3.3, 5.0		1		µA
Supply Current, shutdown enabled	$\overline{\text{PWRSAVE}} = V_{CC} /\text{GND}$, $\overline{\text{SD}} = \text{GND}$, TTL I/P = V _{CC} /GND, RS-232 I/P=float	3.3, 5.0		1		µA
LOGIC Input						
Input Threshold Low		3.3, 5.0			0.8	V
Input Threshold High		5.0	2.4			V
		3.3	2			V
Input Hysteresis		3.3, 5.0		0.3		V
Input Leakage Current	V _{IN} = V _{CC} and GND	3.3, 5.0			±1	µA
LOGIC Output						
Output Voltage Low	I _{OUT} = 1.6mA	3.3, 5.0			0.4	V
Output voltage High	I _{OUT} = -1mA	3.3, 5.0	V _{CC} -0.6	V _{CC} -0.1		V
Output Leakage Current	Receiver O/P disabled, V _{OUT} = V _{CC} or GND	3.3, 5.0		±0.05		µA
Receiver Input						



Input Voltage Range		3.3, 5.0	-15		+15	V
Input Threshold Low		5.0	0.8	1.5		V
		3.3	0.6	1.2		V
Input Threshold High		3.3, 5.0			2.4	V
Input Hysteresis		3.3, 5.0		0.3		V
Input Resistance	$V_{IN} = \pm 25V$	3.3, 5.0	3		7	k Ω
Transmitter Output						
Output Voltage Swing	$R_L = 3-7k$, all loaded	3.3, 5.0	± 5			V
Output Resistance	$V_{CC} = V_{DD} = V_{SS} = GND$, $V_{OUT} = \pm 2V$	0	300			Ω
Output Short-circuit Current	$V_{OUT} = GND$	3.3, 5.0			± 60	mA
Output Leakage Current	Transmitter disabled, $V_{OUT} = \pm 12V$	0, 3.3, 5.0			± 25	μA
Timing Characteristics						
Maximum Data Rate						
< standard speed >	$R_L = 3-7k$, $C_L = 50pF-1000pF$, 1 DR/RC switching	3.3, 5.0	250			kbps
< high speed >	$R_L = 3-7k$, $C_L = 50pF-1000pF$, 1 DR/RC switching	3.3, 5.0	1000			kbps
Transition-Region Slew Rate						V/ μs
< standard speed >	$R_L = 3-7k$, $C_L = 50pF-1000pF$, 1 DR/RC switching	3.3, 5.0		30		V/ μs
< high speed >	$R_L = 3-7k$, $C_L = 50pF-1000pF$, 1 DR/RC switching	3.3, 5.0		90		V/ μs
Transmitter Propagation t_{PLH}	$3k+1000pF$, all loaded	3.3, 5.0		2		μs
Transmitter Propagation t_{PHL}	$3k+1000pF$, all loaded	3.3, 5.0		2		μs
Transmitter Skew	$t_{PHL} - t_{PLH}$	3.3, 5.0		100		ns
Transmitter Output Enable Time		3.3, 5.0		400		ns
Transmitter Output Disable Time		3.3, 5.0		250		ns
Receiver Propagation t_{PLH}	$C_L = 150pF$	3.3, 5.0		0.15		μs
Receiver Propagation t_{PHL}	$C_L = 150pF$	3.3, 5.0		0.15		μs
Receiver Skew	$t_{PHL} - t_{PLH}$	3.3, 5.0		50		ns
Receiver Output Enable Time		3.3, 5.0		0.2		μs
Receiver Output Disable Time		3.3, 5.0		0.2		μs
AutoGreen Timing						
Receiver I/P to \overline{STATE} Output High		3.3, 5.0		1		μs
Receiver I/P to \overline{STATE} Output Low		3.3, 5.0		30		μs
Power save mode to transmitter enabled		3.3, 5.0		100		μs
ESD Tolerance						
ESD HBM		3.3, 5.0		± 15		kV
ESD 1000-4-2 Contact		3.3, 5.0		± 8		kV
ESD 1000-4-2 Air		3.3, 5.0		± 15		kV

Pin Description

PIN							NAME	FUNCTION
KY3220	KY3221	KY3222	KY3223	KY3232	KY3243			
16Pins	16Pins	20Pin	20Pins	16Pins	28Pins	32Pins		
1	1	1	1	—	—	—	\overline{EN}	Receiver Enable Control. Drive low for normal operation. Drive high to force the receiver outputs into a high-Z state.
5	5	5	5	4	1	29	C2+	Positive terminal of inverting charge-pump capacitor
6	6	6	6	5	2	30	C2-	Negative terminal of inverting charge-pump capacitor
7	7	7	7	6	3	31	V-	-5.5V generated by the charge pump
8	8	9, 16	9, 16	8,13	4,5,6,7,8	1,2,3,4,5	R_IN	RS-232 Receiver Inputs
13	13	8, 17	8, 17	7,14	9,10,11	6,7,8	T_OUT	RS-232 Transmitter Outputs
11	11	12, 13	12, 13	10,11	12,13,14	10,11,12	T_IN	TTL/CMOS Transmitter Inputs
9	9	10, 15	10, 15	9,12	15,16,17,18,19	13,14,15,17,18	R_OUT	TTL/CMOS Receiver Outputs
—	—	—	—	—	20	19	ROUTB	TTL/CMOS level, noninverting, always enabled receiver outputs.



—	10	—	11	—	21	20	$\overline{\text{STATE}}$ (INVALID)	Output of the valid signal detector. Indicates if a valid RS-232 level is present on receiver inputs logic “1”.
16	16	20	20	—	22	21	$\overline{\text{SD}}$	Drive low to shut down transmitters and on-board power supply. This overrides all automatic circuitry and $\overline{\text{PWRSAVE}}$
—	12	—	14	—	23	22	$\overline{\text{PWRSAVE}}$	Drive high to override automatic circuitry keeping transmitters on ($\overline{\text{SD}}$ must be high)
4	4	4	4	3	24	23	C1-	Negative terminal of the voltage doubler charge-pump capacitor
14	14	18	18	15	25	24	GND	Ground
15	15	19	19	16	26	26	Vcc	+3.0V to +5.5V Supply Voltage
3	3	3	3	2	27	27	V+	+5.5V generated by the charge pump
2	2	2	2	1	28	28	C1+	Positive terminal of the voltage doubler charge-pump capacitor

Truth Table

Operation Status	$\overline{\text{PWRSAVE}}$	$\overline{\text{SD}}$	$\overline{\text{EN}}$	Signal at RXIN	$\overline{\text{STATE}}$	T _X OUT	R _X OUT
Shutdown	don't care	0	0	present	1	tri-state	active
	don't care	0	0	not present	0	tri-state	active
	don't care	0	1	present	1	tri-state	tri-state
	don't care	0	1	not present	0	tri-state	tri-state
Normal without $\overline{\text{PWRSAVE}}$	1	1	0	present	1	active	active
	1	1	0	not present	0	active	active
	1	1	1	present	1	active	tri-state
	1	1	1	not present	0	active	tri-state
Normal with $\overline{\text{PWRSAVE}}$	0	1	0	present	1	active	active
	0	1	0	not present	0	tri-state	active
	0	1	1	present	1	active	tri-state
	0	1	1	not present	0	tri-state	tri-state

Detailed Description

Charge-Pump

The KY32xx's family utilizes regulated on-chip dual charge pumps that provides output voltages of +5.5V(doubling charge pump) and -5.5V (inverting charge pump), regardless of the input voltage (V_{CC}) over the +3.0V to +5.5V range. The charge pumps operate in a discontinuous mode: if the output voltages are less than 5.5V, the charge pumps are enabled; if the output voltages exceed 5.5V, the charge pumps are disabled. Each charge pump requires a flying capacitor (C1, C2) and a reservoir capacitor (C3, C4) to generate the V+ and V- supplies.

RS-232 Transmitters

The transmitters are proprietary, low dropout, inverting

level translators that convert TTL/CMOS inputs to EIA/TIA-232 output levels. Coupled with the on-chip 5.5V supplies, these transmitters deliver true RS-232 levels over a wide range of single supply system voltages. When $\overline{\text{SD}}$ is driven to ground, or the POWERSAVE circuitry senses invalid voltage levels at all receiver inputs, the transmitters are disabled and the outputs are forced into a high-impedance state.

RS-232 Receive

The KY32xx's receivers convert RS-232 signals to CMOS-logic output levels. They contain standard inverting receivers that three-state (except for the KY3232, KY3243) via the $\overline{\text{EN}}$ or $\overline{\text{SD}}$ control lines.

Controlled Power-Down

The KY3220, KY3221, KY3222, KY3223 and KY3243 have a low-power shutdown mode controlled by the \overline{SD} pin. During shutdown the driver output and the switch-capacitor regulated voltage converter are disabled with the supply current falls to less than $1\mu A$. The KY3221, KY3223 and KY3243 use KEYSEMI's patent pending POWERSAVE circuitry to set/reset latches, which enable the circuit shutdown function when a RS232 cable is disconnected or when the peripheral is turned off and reduce the power supply drain to $1\mu A$ supply current. When a RS232 cable is connected or when the peripheral is enabled, the devices will automatically become active again.

ESD Immunity

The KY32xx series incorporates ruggedized ESD cells on all driver output and receiver input pins.

The ESD structure is improved for more rugged applications and environments sensitive to electro-static discharges and associated transients.

The improved ESD tolerance is at least +15kV without damage nor latch-up.

There are two methods within EN61000-4-2, the Air Discharge method and the Contact Discharge method.

With the Air Discharge Method, an ESD voltage is applied to the equipment under test through air, which simulates an electrically charged person ready to connect a cable onto the rear of the system and the high energy potential on the person discharges through an arcing path to the rear panel of the system before he or she even touches the system.

The Contact Discharge Method applies the ESD current

directly to the EUT.

This method was devised to reduce the unpredictability of the ESD arc.

The discharge current rise time is constant since the energy is directly transferred without the air-gap arc inconsistencies.

KEYSEMI's RS232 transceivers meets and exceeds the minimum criteria for EN61000-4-2 with $\pm 15kV$ for Air Gap Discharge and $\pm 8kV$ for Contact Discharge.

The circuit models in following Figures represent the typical ESD testing circuit.

The CS is initially charged with the DC power supply when the first switch (SW1) is on.

Now that the capacitor is charged, the second switch (SW2) is on while SW1 switches off.

The voltage stored in the capacitor is then applied through RS, the current limiting resistor, onto the device under test (DUT).

In ESD tests, the SW2 switch is pulsed so that the device under test receives a duration of voltage.

For the Human Body Model, the current limiting resistor (RS) and the source capacitor (CS) are $1.5k\Omega$ and $100pF$, respectively. For IEC-61000-4-2, the current limiting resistor (RS) and the source capacitor (CS) are 330Ω and $150pF$, respectively.

The higher CS value and lower RS value in the IEC61000-4-2 model are more stringent than the Human Body Model.

The larger storage capacitor injects a higher voltage to the test point when SW2 is switched on.

The lower current limiting resistor increases the current charge onto the test point.

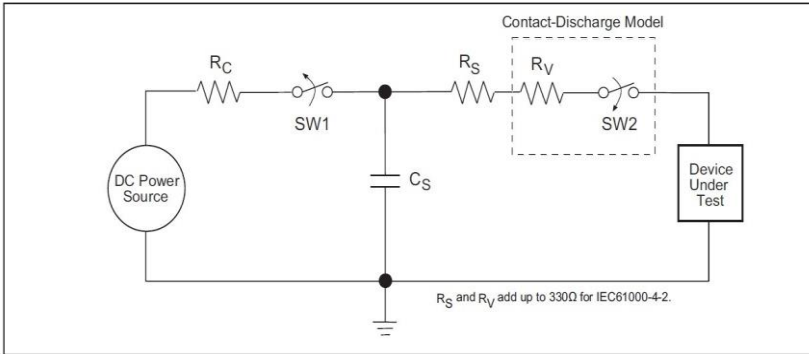

ESD Test Circuit for IEC61000-4-2

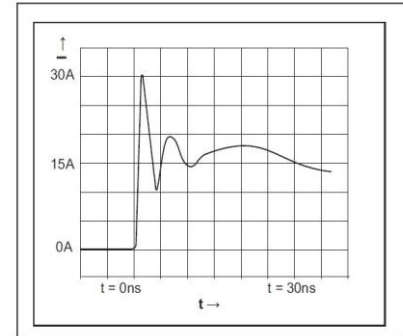

ESD Test Waveform for IEC61000-4-2

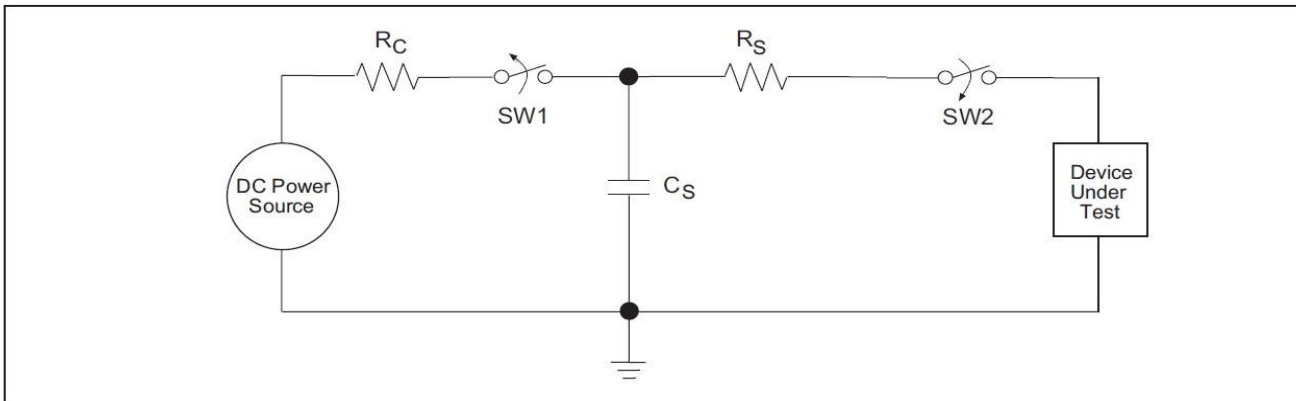

ESD Test Circuit for Human Body Model

DEVICE PIN TESTED	HUMAN BODY MODEL	IEC61000-4-2		
		Air Discharge	Direct Contact	Level
Driver Outputs	$\pm 15\text{kV}$	$\pm 15\text{kV}$	$\pm 8\text{kV}$	4
Receiver Inputs	$\pm 15\text{kV}$	$\pm 15\text{kV}$	$\pm 8\text{kV}$	4

Transceiver ESD Tolerance Levels

Typical Application Circuits and Pin Configuration

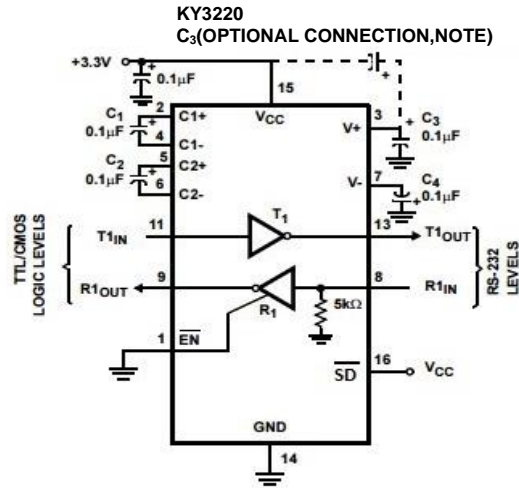
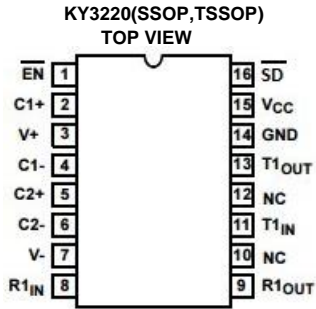

NOTE: The negative terminal of C₃ can be connected to either V_{CC} or GND

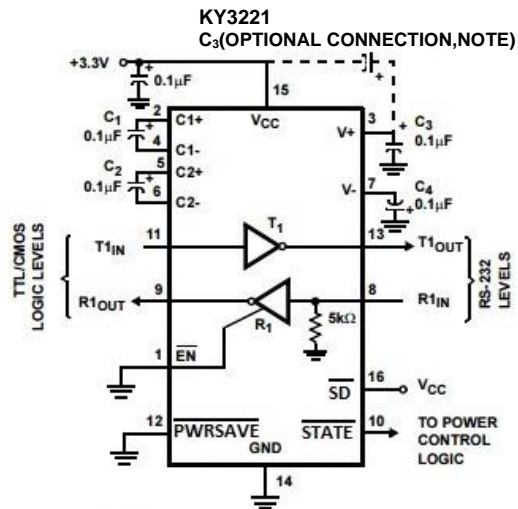
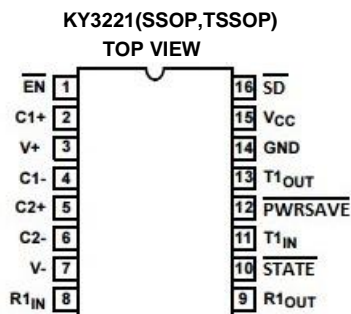

NOTE: The negative terminal of C₃ can be connected to either V_{CC} or GND

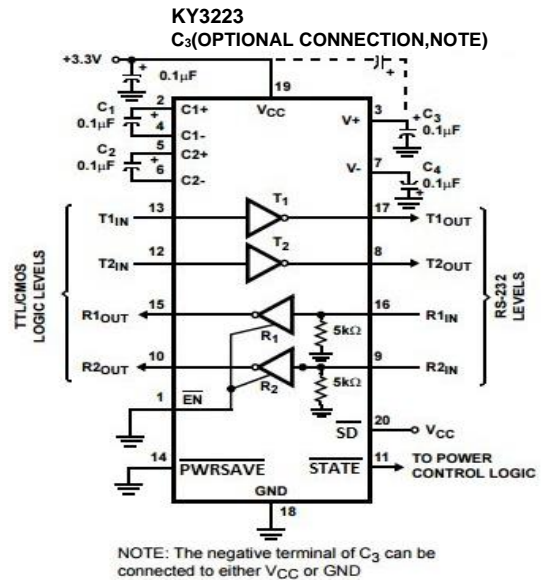
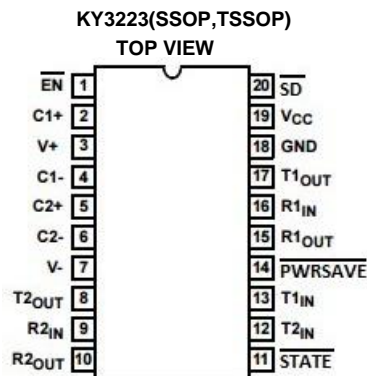
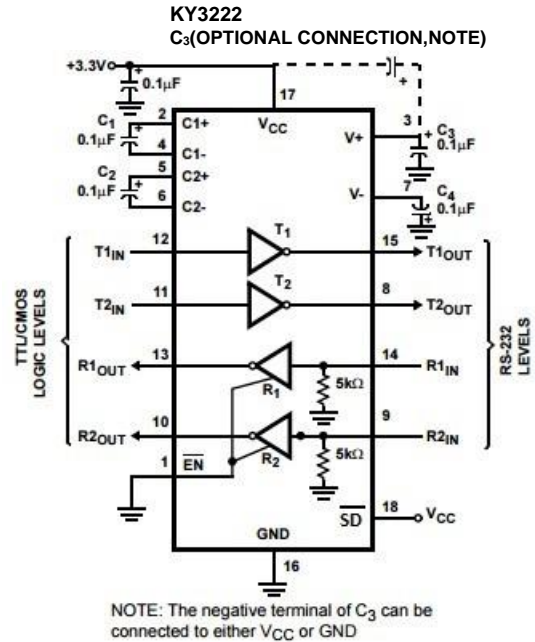
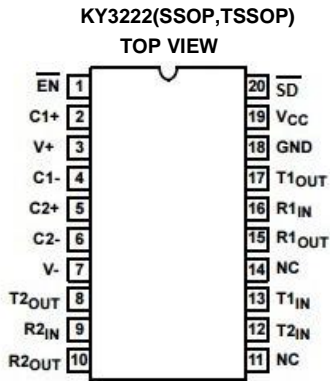



KY3232(nSOIC,SSOP,TSSOP) TOP VIEW

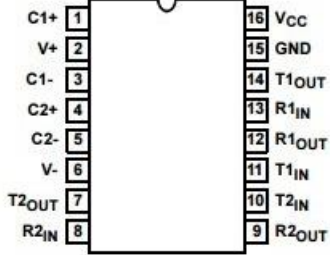

KY3232 C₃(OPTIONAL CONNECTION,NOTE)

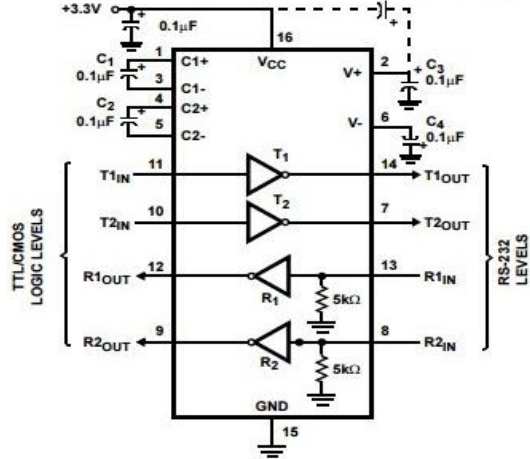

NOTE: The negative terminal of C₃ can be connected to either V_{CC} or GND

KY3243(SSOP,TSSOP) TOP VIEW

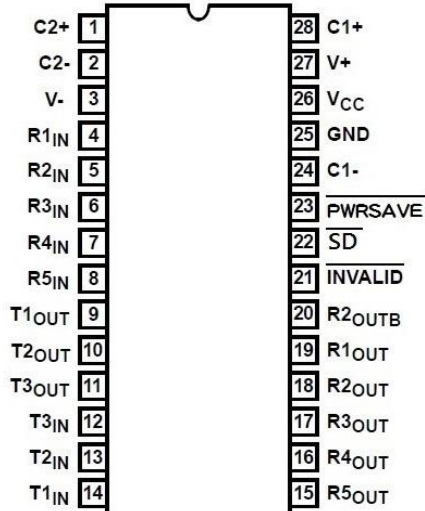

KY3243

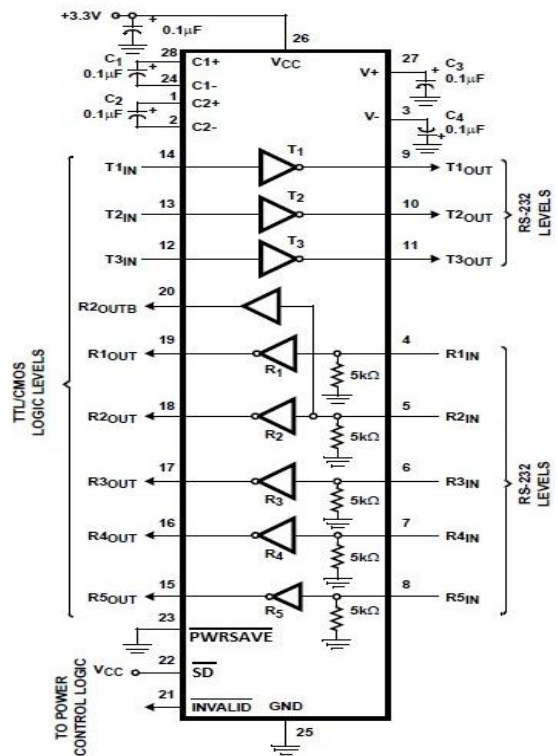

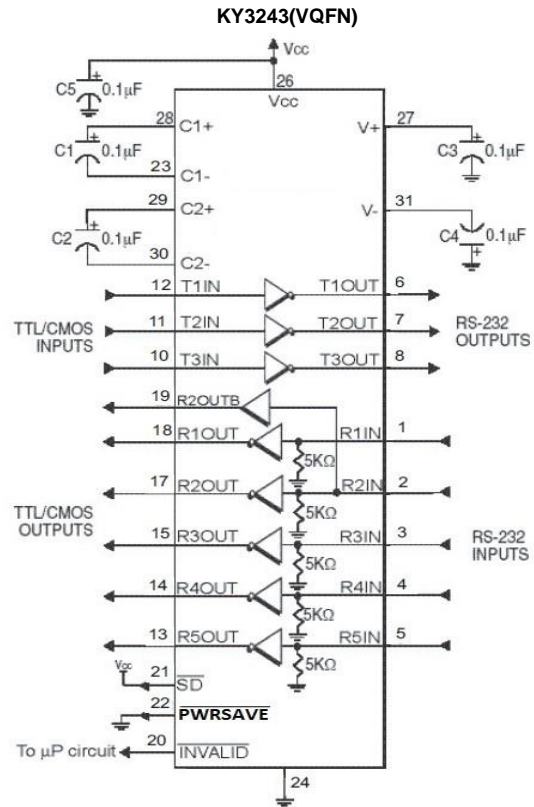
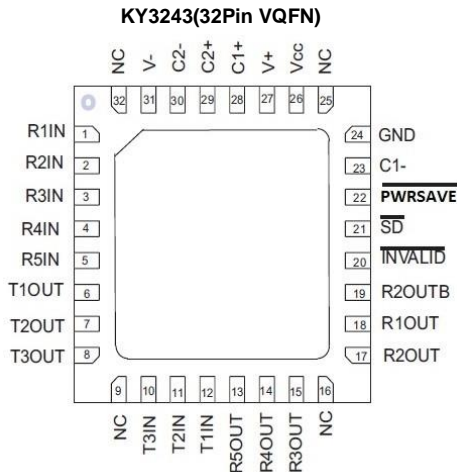

Typical Test Circuits

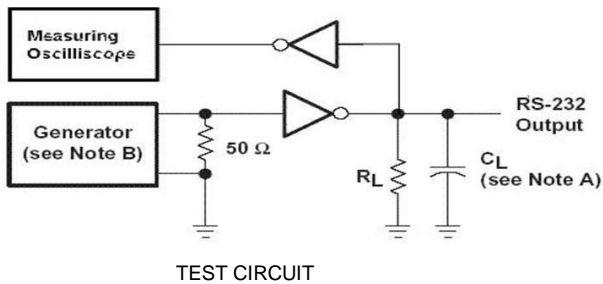

Maximum Data Rate Test Circuit

Notes:

- A. $R_L=3k\Omega$, $C_L = 1000pF$, $T_A = 25^\circ C$, One Driver Switching.
- B. The pulse generator had the following characteristics:
 $PRR = 250$ kbps, $Z_o = 50\Omega$, 50% duty cycle, T_r & $T_f \leq 10ns$.
- C. $\overline{SD} = V_{CC}$ when applicable.

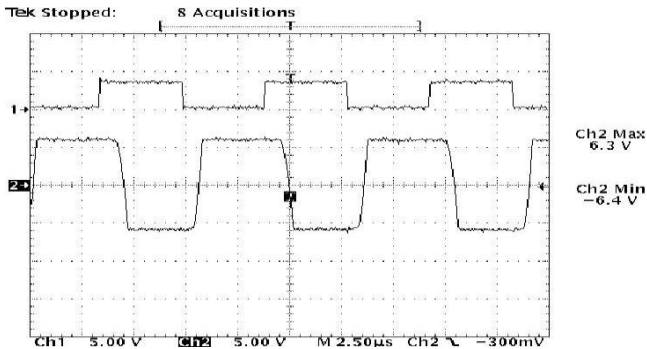

KY32xx TxIN to TxOut (no load) at 250kbps waveform

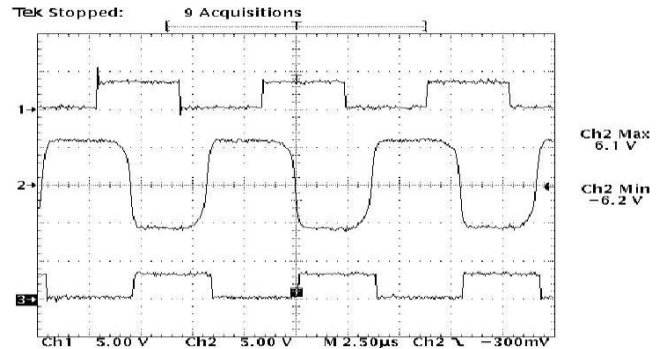

KY32xx TxIN to TxOut to RxOut (loopback to Rx with 100pF load) at 250kbps waveform

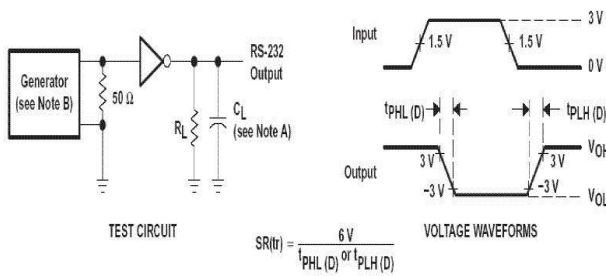

Driver Transition-Region Slew Rate Test Circuit

Notes:

- A. $R_L=3k\sim 7k\Omega, C_L=150\sim 1000pF, T_A=25^\circ C$
One Driver Switching, Measured from +3V to -3V or -3V to +3V.
- B. The pulse generator had the following characteristics:
 $PRR=250\text{ kbps}, Z_o=50\Omega, 50\%$ duty cycle, T_r & $T_f \leq 10ns$.
- C. $\overline{SD} = V_{cc}$ when applicable.

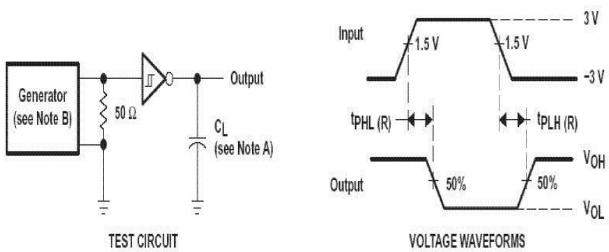

Driver Propagation (t_{PHL} & t_{PLH}) Test Circuit

Notes:

- A. All drivers loaded with $R_L=3k\Omega, C_L=1000pF$.
- B. The pulse generator had the following characteristics:
 $PRR=250\text{ kbps}, Z_o=50\Omega, 50\%$ duty cycle, T_r & $T_f \leq 10ns$.
- C. $\overline{SD} = V_{cc}$ when applicable.

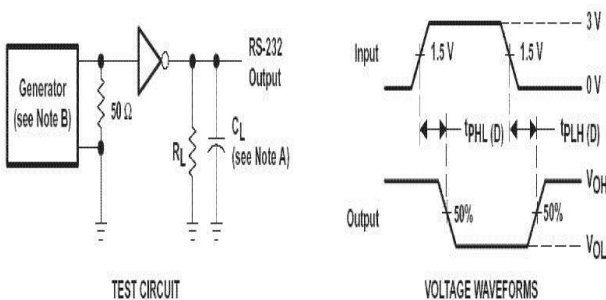

Receiver Propagation Delay Times Test Circuit

Notes:

- A. $C_L=150pF$, including probe and jig capacitance.
- B. The pulse generator had the following characteristics:
 $PRR=250\text{ kbps}, Z_o=50\Omega, 50\%$ duty cycle, T_r & $T_f \leq 10ns$.
- C. $\overline{SD} = V_{cc}$ when applicable.

Package Information

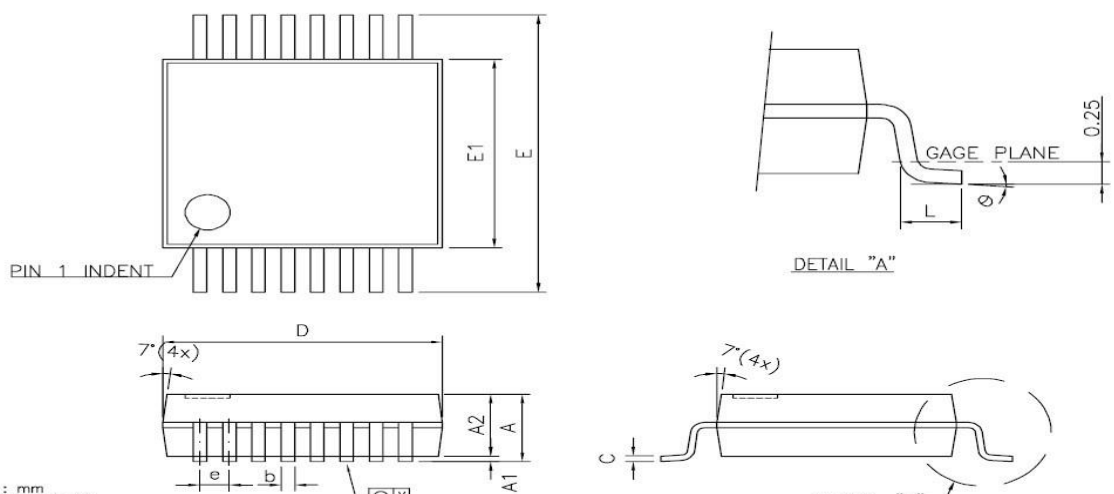

NOTE :

1. CONTROLLING DIMENSION : mm
2. LEAD FRAME MATERIAL : COPPER 194
3. DIMENSION "D" DOES NOT INCLUDE MOLD FLASH, TIE BAR BURRS AND GATE BURRS. MOLD FLASH, TIE BAR BURRS AND GATE BURRS SHALL NOT EXCEED 0.006"[0.15mm] PER END DIMENSION "E1" DOES NOT INCLUDE INTERLEAD FLASH. INTERLEAD FLASH SHALL NOT EXCEED 0.010"[0.25mm] PER SIDE.
4. DIMENSION "b" DOES NOT INCLUDE DAMBAR PROTRUSION. ALLOWABLE DAMBAR PROTRUSION SHALL BE 0.003"[0.08mm] TOTAL IN EXCESS OF THE "b" DIMENSION AT MAXIMUM MATERIAL CONDITION. DAMBAR CANNOT BE LOCATED ON THE LOWER RADIUS OR THE FOOT. MINIMUM SPACE BETWEEN PROTRUSION AND AN ADJACENT LEAD TO BE 0.0028"[0.07mm]
5. TOLERANCE : ±0.010"[0.25mm] UNLESS OTHERWISE SPECIFIED.
6. OTHERWISE DIMENSION FOLLOW ACCEPTABLE SPEC.
7. REFERENCE DOCUMENT : JEDEC SPEC MO-150AC

SYMBOLS	DIMENSIONS IN MILLIMETERS			DIMENSIONS IN INCHES		
	MIN	NOM	MAX	MIN	NOM	MAX
A	—	—	2.00	—	—	0.079
A1	0.05	—	0.15	0.002	—	0.006
A2	1.65	1.75	1.85	0.065	0.069	0.073
b	0.22	0.30	0.38	0.0086	0.012	0.015
C	0.09	0.15	0.25	0.0035	0.006	0.0098
D	5.90	6.20	6.50	0.232	0.244	0.256
E	7.40	7.80	8.20	0.291	0.307	0.323
E1	5.00	5.30	5.60	0.197	0.209	0.220
e	—	0.65	—	—	0.0256	—
L	0.55	0.75	0.95	0.022	0.030	0.037
φ	0"	4"	8"	0"	4"	8"
y	—	—	0.10	—	—	0.004

16-pin SSOP

CUSTOMER :		TITLE:	
APPROVED BY :	DATE :	16L SSOP PACKAGE OUTLINE DRAWING (BODY SIZE: 5.3mm)	
DRAW BY :		DWG. NO. :	PO-SSOP-016
CHECK BY :		REV. :	0
APPROVAL :		UNIT :	mm
APPROVAL :		SCALE :	12/1
		SHEET :	1 OF 1

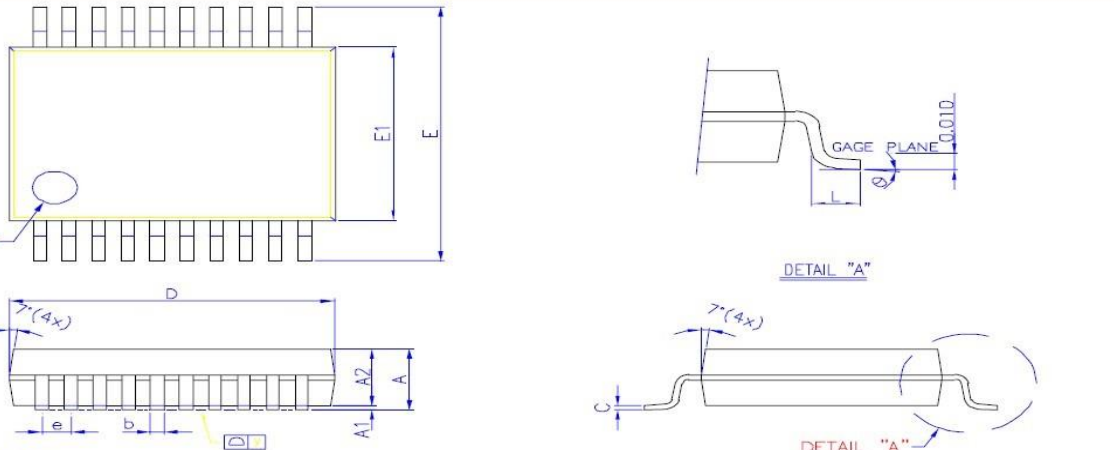

NOTE :

1. CONTROLLING DIMENSION : INCH
2. LEAD FRAME MATERIAL : COPPER 194
3. DIMENSION "D" DOES NOT INCLUDE MOLD FLASH, TIE BAR BURRS AND GATE BURRS. MOLD FLASH, TIE BAR BURRS AND GATE BURRS SHALL NOT EXCEED 0.006"[0.15mm] PER END DIMENSION "E1" DOES NOT INCLUDE INTERLEAD FLASH. INTERLEAD FLASH SHALL NOT EXCEED 0.010"[0.25mm] PER SIDE.
4. DIMENSION "b" DOES NOT INCLUDE DAMBAR PROTRUSION. ALLOWABLE DAMBAR PROTRUSION SHALL BE 0.003"[0.08mm] TOTAL IN EXCESS OF THE "b" DIMENSION AT MAXIMUM MATERIAL CONDITION. DAMBAR CANNOT BE LOCATED ON THE LOWER RADIUS OR THE FOOT. MINIMUM SPACE BETWEEN PROTRUSION AND AN ADJACENT LEAD TO BE 0.0028"[0.07mm]
5. TOLERANCE : ±0.010"[0.25mm] UNLESS OTHERWISE SPECIFIED.
6. OTHERWISE DIMENSION FOLLOW ACCEPTABLE SPEC.
7. REFERENCE DOCUMENT : JEDEC SPEC MO-150

SYMBOLS	DIMENSIONS IN MILLIMETERS			DIMENSIONS IN INCHES		
	MIN	NOM	MAX	MIN	NOM	MAX
A	—	—	2.00	—	—	0.079
A1	0.05	—	—	0.002	—	—
A2	—	1.75	—	—	0.069	—
b	0.22	0.30	0.38	0.0086	0.012	0.015
C	0.13	0.15	0.20	0.0051	0.006	0.0079
D	7.08	7.20	7.34	0.279	0.284	0.289
E	7.40	7.80	8.20	0.291	0.307	0.323
E1	5.00	5.30	5.60	0.197	0.209	0.220
e	—	0.65	—	—	0.0256	—
L	0.56	0.75	0.97	0.022	0.030	0.037
φ	—	4"	8"	—	4"	8"
y	—	—	0.076	—	—	0.003

20-pin SSOP

CUSTOMER :		TITLE:	
APPROVED BY :	DATE :	20L MEDIUM FINE PITCH STANDARD SMALL OUTLINE PACKAGE DRAWING	
DRAW BY :		DWG. NO. :	PO-SSOP-010
CHECK BY :		REV. :	0
APPROVAL :		UNIT :	INCH
APPROVAL :		SCALE :	12/1
		SHEET :	1 OF 1

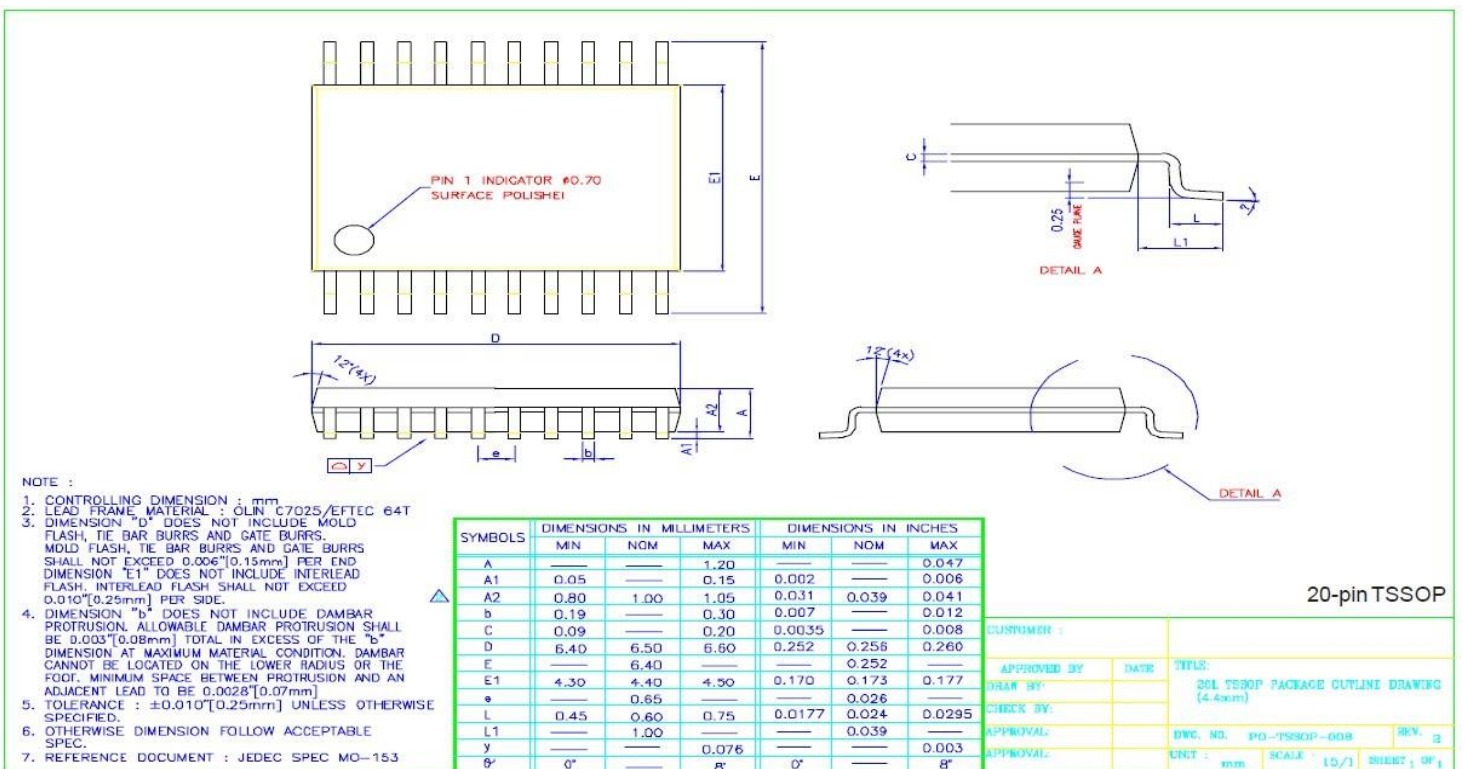
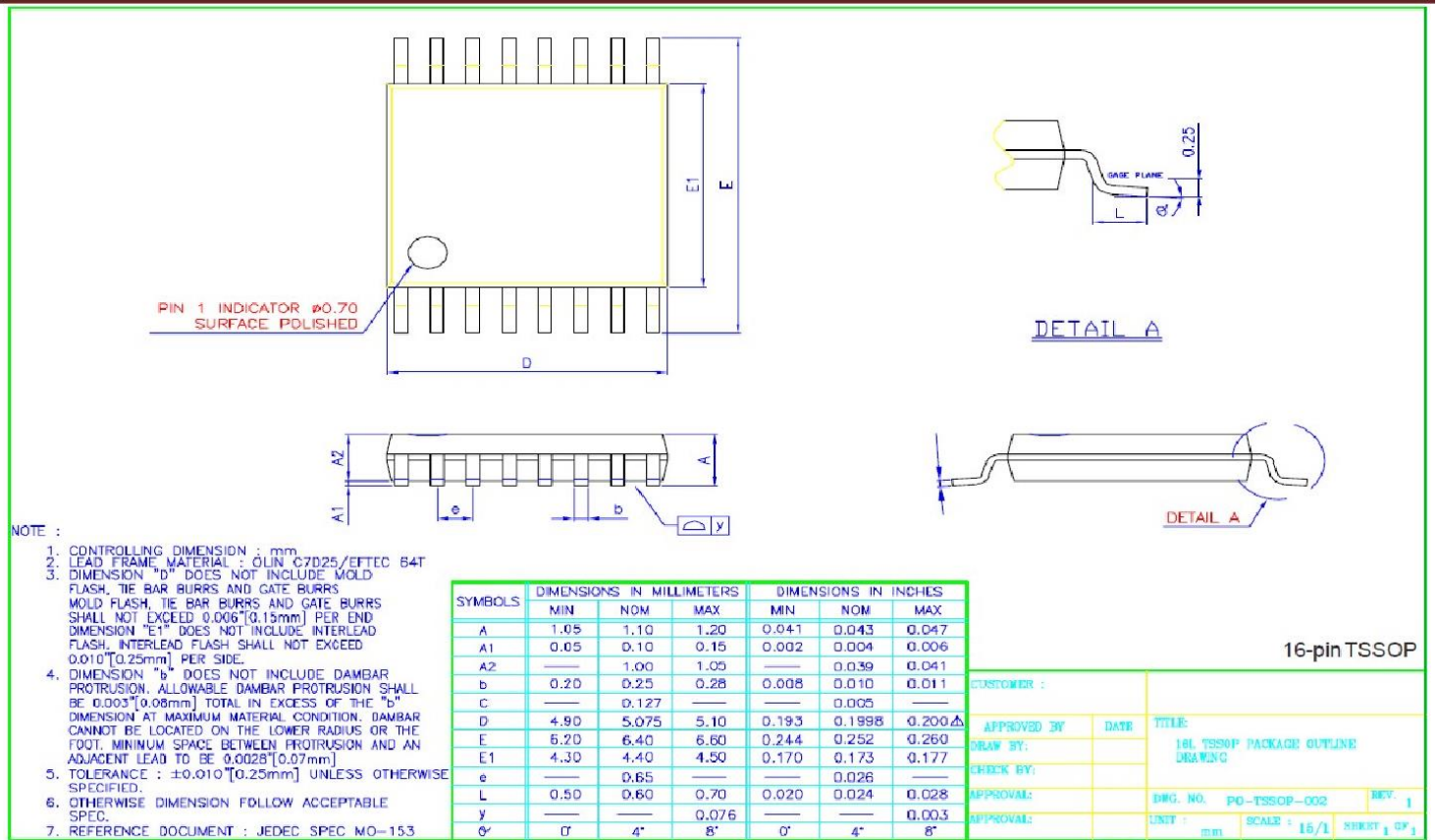

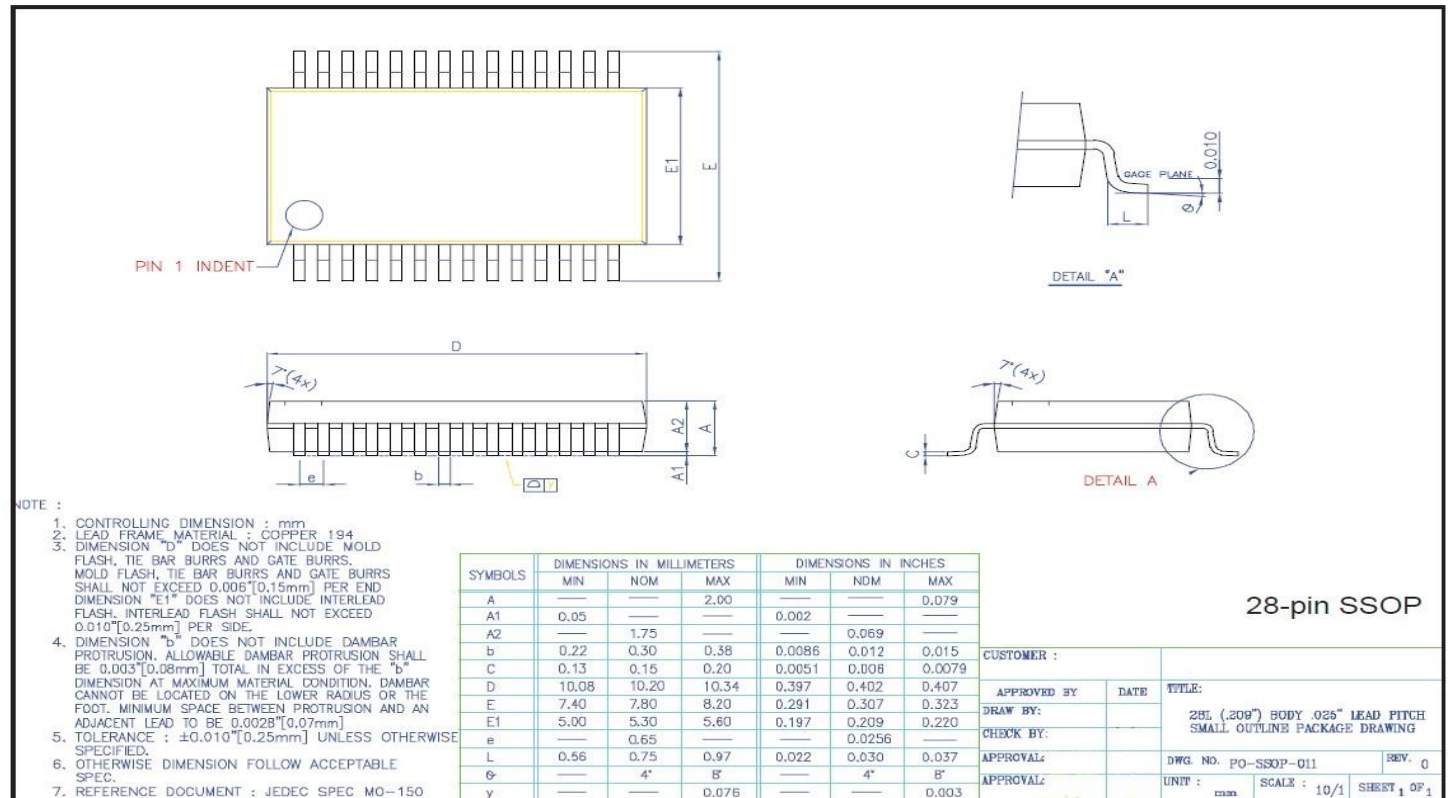
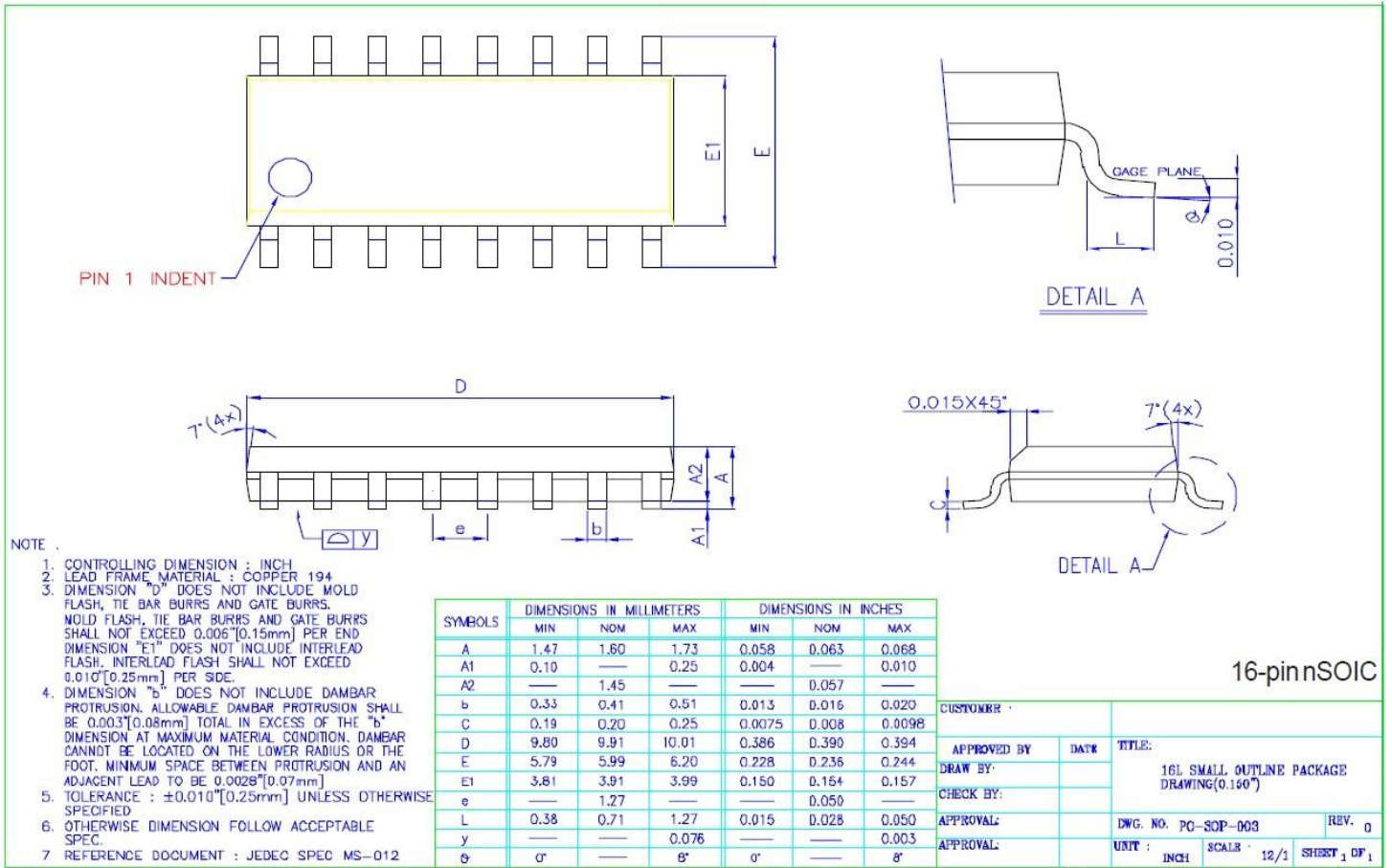

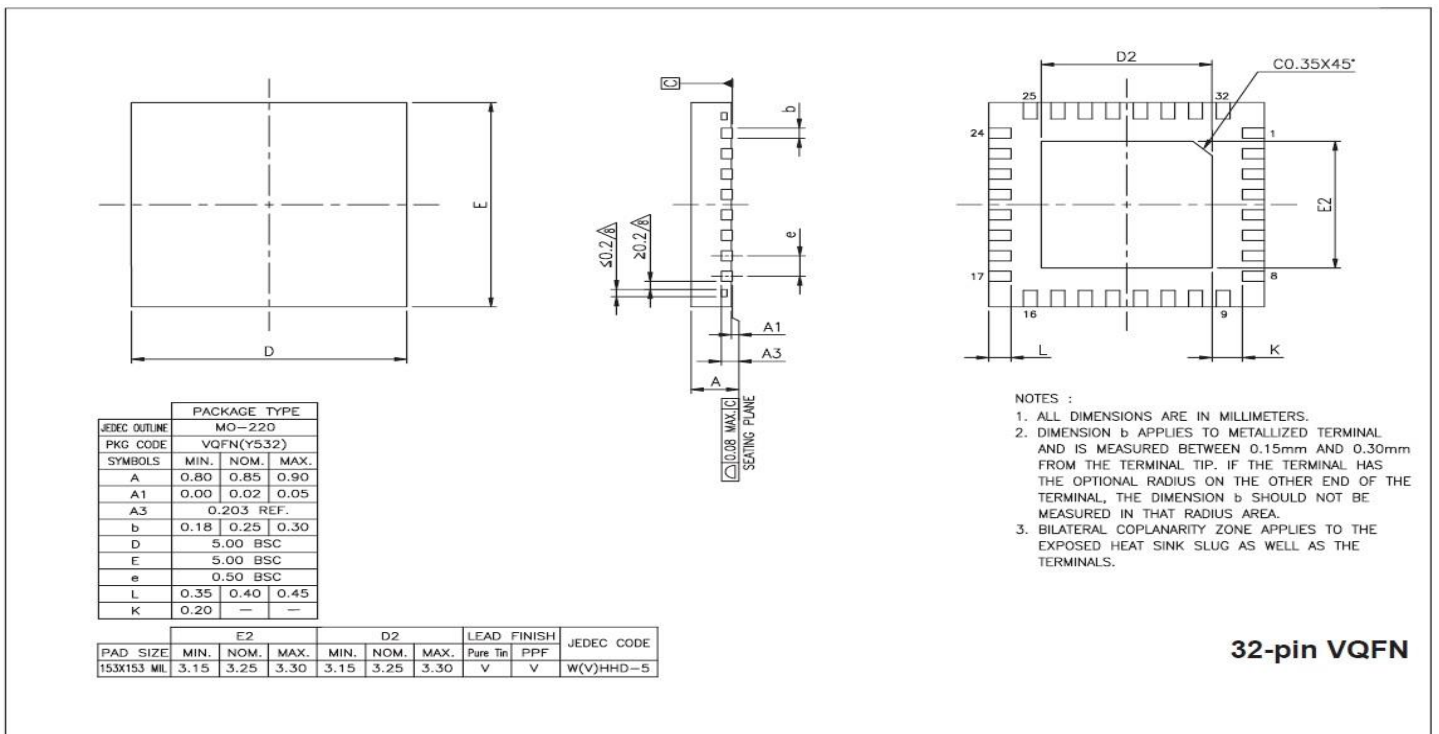
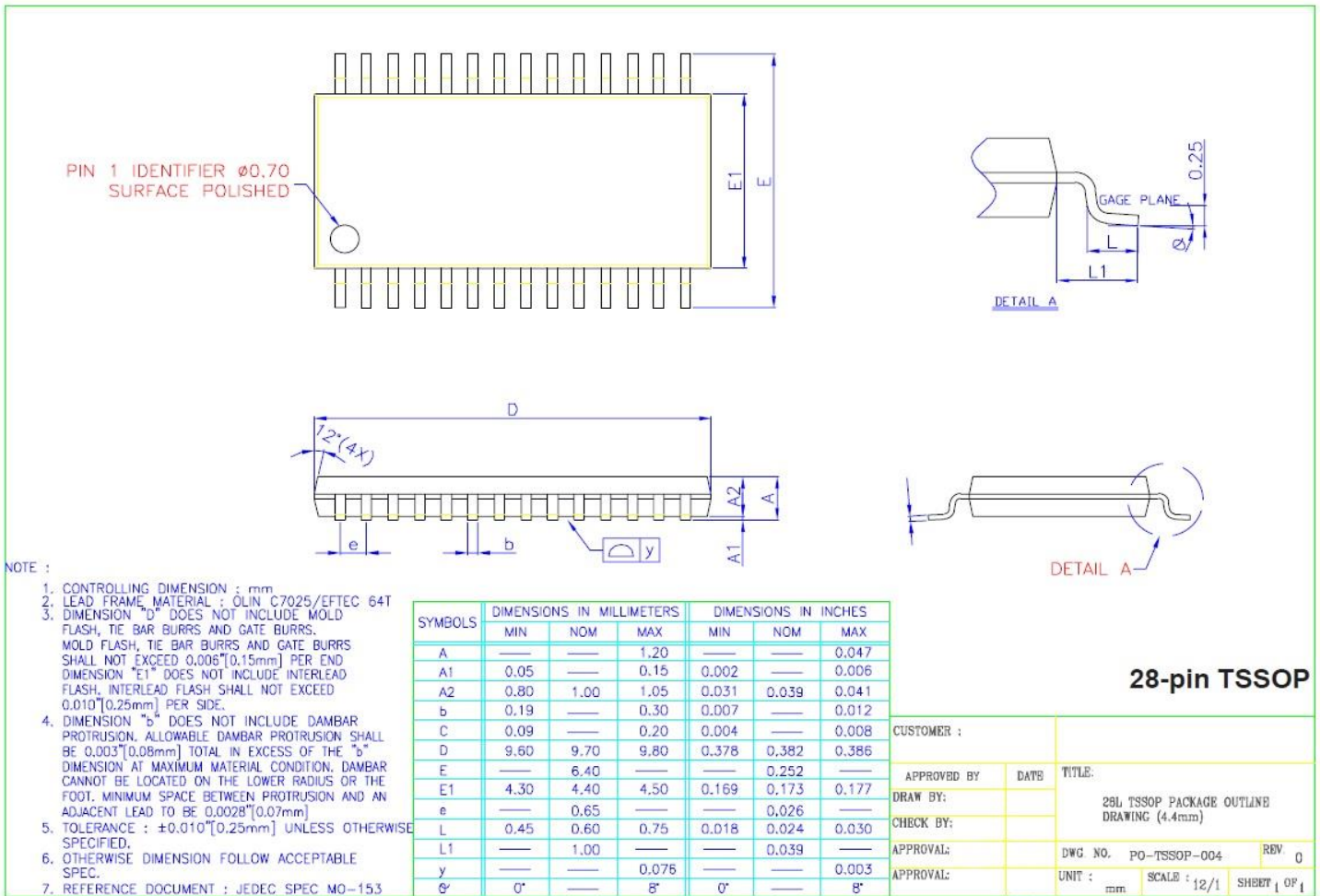

Ordering Information

Part No.	Order Part No.	Temperature Range	Package Type
KY3220LEEA	KY3220LEEA-GE3R	-40°C to +85°C	16-pin SSOP
KY3220LEEY	KY3220LEEY-GE3R	-40°C to +85°C	16-pin TSSOP
KY3221LEEA	KY3221LEEA-GE3R	-40°C to +85°C	16-pin SSOP
KY3221LEEY	KY3221LEEY-GE3R	-40°C to +85°C	16-pin TSSOP
KY3222LEEA	KY3222LEEA-GE3R	-40°C to +85°C	20-pin SSOP
KY3222LEEY	KY3222LEEY-GE3R	-40°C to +85°C	20-pin TSSOP
KY3223LEEA	KY3223LEEA-GE3R	-40°C to +85°C	20-pin SSOP
KY3223LEEY	KY3223LEEY-GE3R	-40°C to +85°C	20-pin TSSOP
KY3232LEEA	KY3232LEEA-GE3R	-40°C to +85°C	16-pin SSOP
KY3232LEEN	KY3232LEEN-GE3R	-40°C to +85°C	16-pin nSOIC
KY3232LEEY	KY3232LEEY-GE3R	-40°C to +85°C	16-pin TSSOP
KY1385LEEA	KY1385LEEA-GE3R	-40°C to +85°C	20-pin SSOP
KY3243LEEA	KY3243LEEA-GE3R	-40°C to +85°C	28-pin SSOP
KY3243LEEY	KY3243LEEY-GE3R	-40°C to +85°C	28-pin TSSOP
KY3243LEEQ	KY3243LEEQ-GE3R	-40°C to +85°C	32-pin VQFN

Part No.	Order Part No.	Temperature Range	Package Type
KY3220LFEA	KY3220LFEA-GE3R	-40°C to +85°C	16-pin SSOP
KY3220LFEY	KY3220LFEY-GE3R	-40°C to +85°C	16-pin TSSOP
KY3221LFEA	KY3221LFEA-GE3R	-40°C to +85°C	16-pin SSOP
KY3221LFEY	KY3221LFEY-GE3R	-40°C to +85°C	16-pin TSSOP
KY3222LFEA	KY3222LFEA-GE3R	-40°C to +85°C	20-pin SSOP
KY3222LFEY	KY3222LFEY-GE3R	-40°C to +85°C	20-pin TSSOP
KY3223LFEA	KY3223LFEA-GE3R	-40°C to +85°C	20-pin SSOP
KY3223LFEY	KY3223LFEY-GE3R	-40°C to +85°C	20-pin TSSOP
KY3232LFEA	KY3232LFEA-GE3R	-40°C to +85°C	16-pin SSOP
KY3232LFEN	KY3232LFEN-GE3R	-40°C to +85°C	16-pin nSOIC
KY3232LFEY	KY3232LFEY-GE3R	-40°C to +85°C	16-pin TSSOP
KY1385LFEA	KY1385LFEA-GE3R	-40°C to +85°C	20-pin SSOP
KY3243LFEA	KY3243LFEA-GE3R	-40°C to +85°C	28-pin SSOP
KY3243LFEY	KY3243LFEY-GE3R	-40°C to +85°C	28-pin TSSOP
KY3243LFEQ	KY3243LFEQ-GE3R	-40°C to +85°C	32-pin VQFN

Please contact the factory for pricing, availability on Tape-and-Reel, and Green Package options.